

CSI 9420 Wireless Vibration Transmitter

- Accurately monitors vibration and temperature in hard-to-reach locations
- Provides complete vibration data including overall levels, energy bands, high resolution spectra, and waveforms
- Includes Emerson's patented PeakVue™ technology for bearing and gear diagnostics
- Certified intrinsically safe for use in hazardous areas
- Delivers data and device alerts securely and reliably via IEC 62591 (*WirelessHART*®) networks
- Easily integrates into any host via Modbus or OPC with detailed diagnostics via AMS Suite software



The CSI 9420 delivers complete vibration information, including high resolution spectra and waveform, over a self-organizing wireless network for use by operations and maintenance personnel.

Overview

The rugged CSI 9420 Wireless Vibration Transmitter is the first device to provide full vibration data over a self-organizing wireless network. It provides rich information about machinery health for both operations and maintenance personnel. Overall vibration, PeakVue, and temperature readings can be easily integrated into any control system or plant historian while diagnostic data can be displayed by AMS Suite: Intelligent Device Manager or any EDDL compliant host. For advanced diagnostics, high resolution data can be delivered to AMS Suite: Machinery Health Manager for trending and analysis.

Cost-Effective, Reliable Monitoring

The CSI 9420 extends vibration monitoring to an entire array of new applications. While appropriate for most vibration monitoring tasks, it is especially well suited for hard-to-reach locations, such as cooling towers, pumping stations, remote equipment, and hazardous areas.

In general, the CSI 9420 provides an excellent solution for any application that might otherwise involve extensive engineering, cabling, or installation costs. Advanced electronics deliver a high level of accuracy, while the IEC-approved *WirelessHART* standard delivers exceptional reliability.

Overall Condition in the Control Room

The CSI 9420 delivers information about the overall health of rotating assets directly to the control room via Modbus or OPC. Overall vibration data is a good indicator of shaft problems such as imbalance, misalignment, or mechanical looseness. In contrast, the PeakVue reading provides a reliable measure of impacting on the machine. As the PeakVue level increases, it provides direct indication of a developing problem, such as improper lubrication, bearing fault, or gear defect. Process induced faults, such as cavitation, are detected by an increase in both the overall vibration and PeakVue readings.

Asset Dashboard at your Fingertips

AMS Device Manager generates an asset dashboard based on the output of the CSI 9420. This intuitive interface displays the health of the sensor, the transmitter, and the production asset being monitored – extending the benefits of PlantWeb® to WirelessHART devices. EDDL capabilities provide graphical presentation of diagnostics and a consistent user interface between manufacturers. When needed, the interface can also be used to view more detailed diagnostic data, including vibration energy bands and thumbnail spectra.



AMS Device Manager uses EDDL technology to create an asset dashboard with clear indication of device and asset status.

Diagnostic Data to the Maintenance Office

AMS Machinery Manager automatically communicates detailed diagnostic data to the maintenance office, including overall values, energy bands, high resolution spectra, and waveforms. Once stored in the AMS Machinery Manager database, these measurements deliver the same diagnostic value as comparable readings collected using Emerson’s industry- leading CSI 2130 Machinery Health Analyzer.

AMS Machinery Manager provides advanced analytical tools to trend vibration levels, generate alerts, and diagnose developing faults.

Information Available When You Need It

When updated readings are required between scheduled measurements, you can initiate on-demand acquisitions from AMS Machinery Manager. This allows you to quickly and easily access current health information about your rotating assets without leaving your desk.

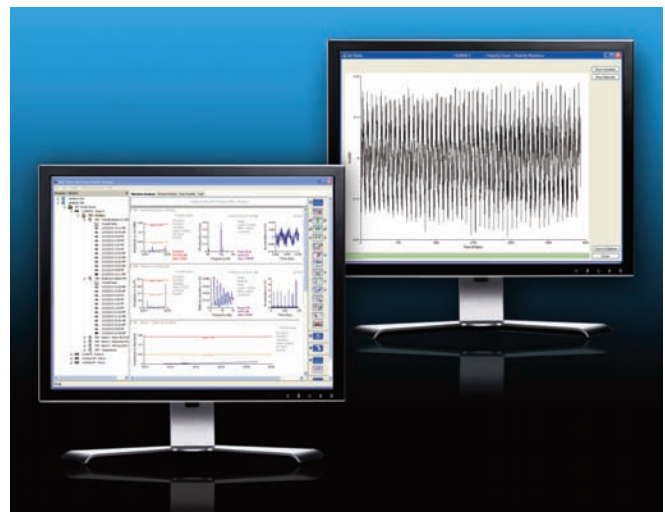

AMS Machinery Manager provides advanced analytical tools to trend vibration levels, generate alerts, and diagnose developing faults.

Flexible Configuration Options

The Power to Get Things Done

There are two power options for the CSI 9420. For a truly wireless experience, utilize the SmartPower™ Module. Based on the low power output defined by the *WirelessHART* standard, the CSI 9420 can achieve an operating life of up to 10 years when using the Power Save option (update rate set to 2 hours). An operating life of 3-4 years can be expected when using the default settings (update rate set to 30 minutes).

For faster update rates, the external DC-powered terminal block is recommended. This option provides virtually unlimited operation, even at the minimum update rate of once per minute.

Local Indication and Verification

The optional LCD display provides a local read-out of sensor values and transmitter diagnostics to streamline commissioning and troubleshooting at the device. Local indication of vibration measurements and diagnostics also provides accurate, real-time verification of operating conditions. The LCD display can be rotated to facilitate easy viewing, regardless of the orientation of the transmitter.

Plan and Manage Wireless Networks

The AMS Wireless SNAP-ON™ application is a revolutionary tool that enables you to both plan and manage your wireless network. Starting with a floor plan or aerial photo of the plant, utilize simple click-and-drag functionality to position the gateways and wireless devices. Then the AMS Wireless SNAP-ON application will compare the plan to industry best practices. Recommendations will help you quickly develop a reliable wireless network.

After the devices are installed, the AMS Wireless SNAP-ON application will help you manage the network, providing a graphical overview of the communication paths and network health.

Wireless Architecture Overview

Ultimate Simplicity

Built on the IEC 62591 (*WirelessHART*) industrial standard, Emerson's wireless network is completely self-organizing. There is no need to configure communication paths because the Smart Wireless Gateway manages this automatically – including adapting to changing environments. Once the network is established, new devices can be added at any time. Conversely, even if a device is de-commissioned, data reporting from other devices continues uninterrupted over other established paths.

Easy Installation

The CSI 9420, like all Emerson's Smart Wireless transmitters, is simple to install. As soon as power is applied to the device, it will automatically establish communication with neighboring wireless devices, establish a path to the Gateway, and begin reporting. Each transmitter also has the ability to function as a repeater, relaying data from other devices to extend the network across virtually any size facility or industrial campus.

Network Stability

The Smart Wireless Gateway connects the wireless network with the host system and data applications like AMS Suite. The Gateway manages all aspects of the network: executing scheduled readings and accommodating requests for on-demand acquisitions. The Gateway configures the network to minimize power consumption and ensure network stability, while maintaining data reliability well above 99%.



The AMS Wireless SNAP-ON application graphically displays your wireless network.

Best-in-Class Security

Emerson’s multi-layered approach to wireless network security builds on the IEC 62591 standard to ensure that your data stays protected – no matter what. Authentication and verification make certain that only authorized devices can join the network, while 128-bit encryption shields your information. Channel hopping maintains operation, even in challenging environments.

Emerson’s Complete Smart Wireless Solution

Emerson has a complete portfolio of Smart Wireless transmitters for many applications, including temperature, pressure, flow, and level. In addition, the Smart Wireless THUM™ Adapter can enable any HART device to wirelessly transmit measurement and diagnostic information. Emerson wireless devices can be accessed and maintained remotely using the same tools and software as wired devices, leveraging existing practices, training, and maintenance procedures.

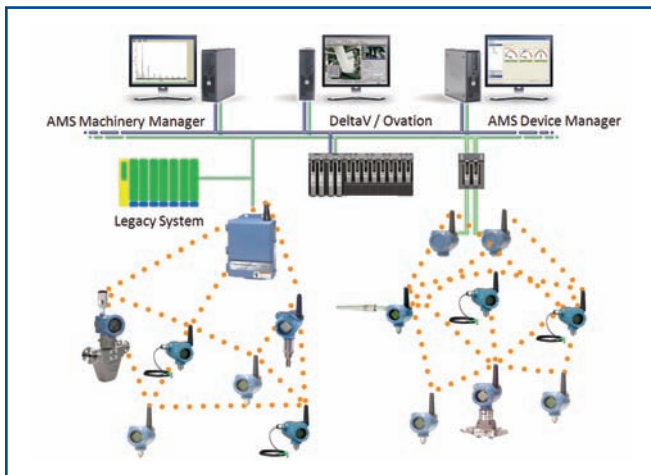

At the heart of Emerson’s Smart Wireless solution is the self-organizing network, featuring tight security, infinite configurability, and data reliability that rivals wired systems.

Seamless Integration to Host Systems

Easily configure and broadcast measurements to Emerson’s DeltaV™ and Ovation™ digital automation systems or any Modbus or OPC compliant host or other automation system or data historian.

Analyze Data in AMS Machinery Manager

Vibration data from the CSI 9420 can be stored and analyzed in AMS Machinery Manager. The Data Import module provides easy data mapping using simple drag-and-drop commands. AMS Machinery Manager combines predictive techniques with comprehensive analysis tools for an accurate assessment of the machinery health in your facility

Detailed Reliability Data

Overall vibration and PeakVue value levels help you identify machines that may be developing mechanical faults. However, once a machine has been flagged, detailed data is required to pinpoint the exact cause and severity of the fault. With the advanced diagnostics in the CSI 9420, you have access to this critical information.

High Resolution Waveform

The vibration waveform (shown below) is the basis for all other vibration measurements performed by the CSI 9420. Each waveform is a complex data set of thousands of samples, collected over several seconds of machine operation.

While the acceleration waveform can be helpful in some applications, the PeakVue waveform is indispensable for diagnosing developing bearing and gear defects. Because of their large size, however, waveforms tend to be collected less frequently. Emerson’s Smart Wireless solution employs several data compression techniques to extract the information while facilitating easier transmission over the network.

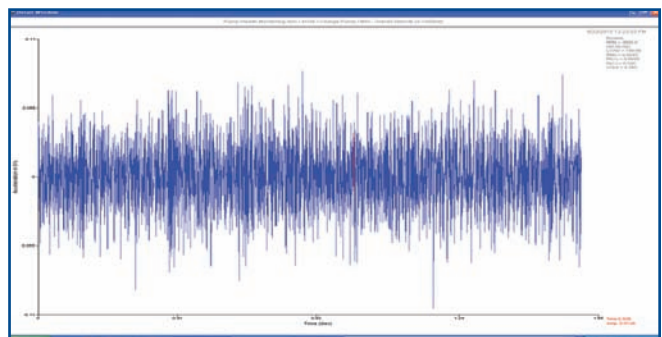

The acceleration waveform contains raw vibration data that allows you to diagnose the health of the asset.

High Resolution Spectrum

The first compression technique is FFT analysis, which transforms the vibration waveform into a frequency spectrum (shown below). This spectrum not only reduces the file size by over 60%, it also presents the frequency information in a more readable format. The smaller data set accelerates responsiveness of the system while reducing power consumption.

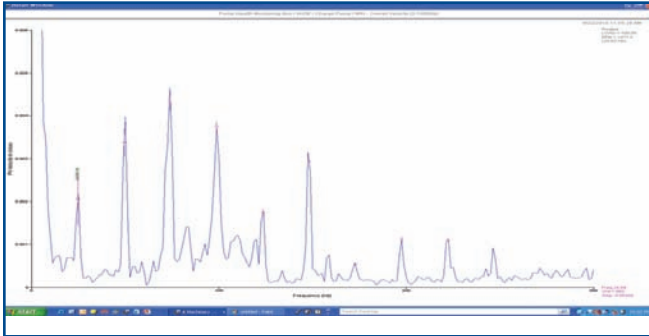

The elevated peaks in this high resolution spectrum provide a clear indication of mechanical looseness on the machine.

Thumbnail Spectrum

The thumbnail spectrum is derived from the same waveform data. It contains the same frequency and amplitude information as the high resolution spectrum, but the data set has been compressed by an additional 98%. Now it is small enough to transfer over the network in less than a second.

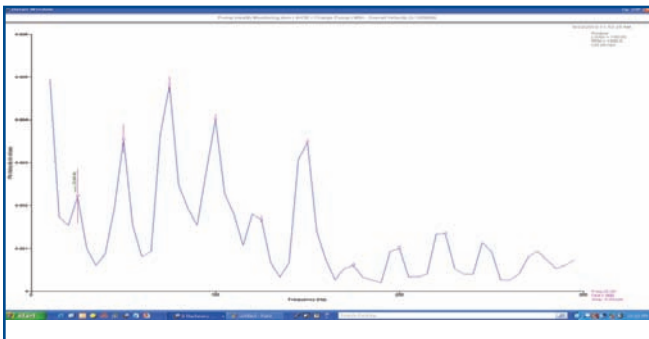

The thumbnail spectrum enables fast, low power operation, yet still offers information similar to the high resolution spectrum shown above.

Energy Bands

As a final data compression technique, the CSI 9420 divides the spectrum into three predetermined energy bands (as shown below). It then calculates the vibration energy within each energy band and passes these values to AMS Machinery Manager for trending and alerts.

Band	Fault Types	Range
1	Rotor Vibration: Imbalance, misalignment (also defects on belt drives)	2–65 Hz
2	Rotor Harmonics: Looseness, electrical faults, blade and vane pass	65–300 Hz
3	High Frequency: Bearing and gear defects, lubrication and cavitation	300–1000 Hz

Energy bands with frequency ranges. Optimized for a 4-pole motor running between 1500 and 1800 RPM. Note: bands are fixed.

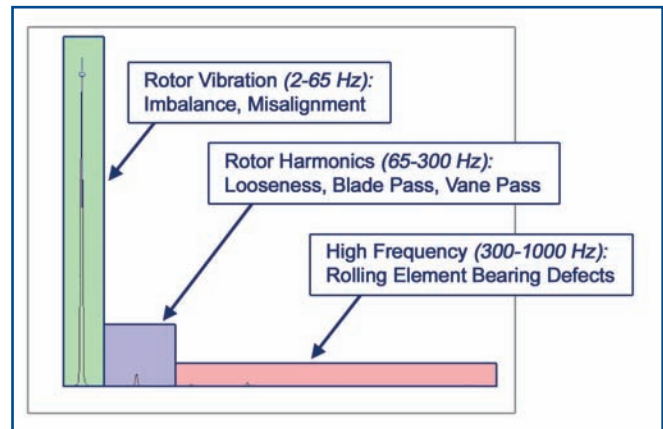

By dividing the spectrum into energy bands, we can isolate frequencies associated with different categories of faults.

By trending the values in AMS Machinery Manager and comparing them to appropriate alert levels, it is possible to set up a system of intelligent alerts that not only inform you when the machine condition is deteriorating, but also provide information about the underlying cause of the problem.

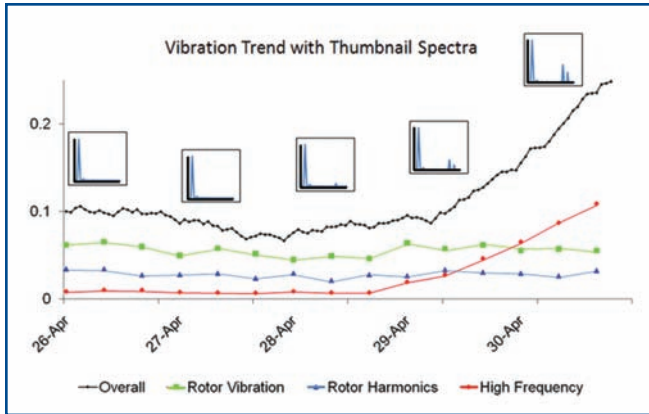

The trend of overall vibration suggests that machine health is deteriorating but without any indication as to the root cause. The trend of the high frequency energy band provides further insight, which can be confirmed by examining the thumbnail spectra.

The figure illustrates how vibration data can be used to detect and diagnose a developing fault. Based on the increase in overall vibration (black line), an alert would flag the machine as having a potential fault – but with no indication at all about the nature or severity of the fault.

The trend of the three energy bands shows that the readings for rotor vibration (green) and rotor harmonics (blue) are stable, while the readings for high frequency vibration (red) have increased sharply. This would trigger a special alert for the rotating equipment specialist in AMS Machinery Manager.

Examination of the thumbnail spectra (shown above the trend) confirms that the fault is high frequency in nature. On-demand acquisition of the PeakVue spectrum and waveform then provides conclusive insight into the specific nature of the fault as well as its severity. Using the advanced diagnostics in the CSI 9420 and AMS Machinery Manager, maintenance personnel can often address and resolve an issue without it ever registering as an alert in the control room.

Functional Specifications

Inputs	
Accelerometer 1	DC Bias Range: 2 - 3 Vdc DC Input Range: 0 - 5 Vdc AC Input Range: 2.5 Vpeak equivalent to 100 g's peak (980 m/s ² peak)
Accelerometer 2	DC Bias Range: 2 - 3 Vdc DC Input Range: 0 - 5 Vdc AC Input Range: 2.5 Vpeak equivalent to 100 g's peak (980 m/s ² peak)
Temperature	DC Input Range: -22°F to 250°F (-30° to + 121°C)
Standard Outputs	
Machinery Health Values:	Velocity overall (1 or 2 sensors) PeakVue overall (1 or 2 sensors) Temperature (1 sensor only)
Transmitter Health Values	Ambient temperature Supply voltage Sensor bias voltage (1 or 2 sensors) Multiple internal alerts indicate the status of device health
Advanced Diagnostic Outputs (optional)	
Energy bands	Rotor vibration (2 - 65 Hz) Rotor harmonics (65 - 300 Hz) High Frequency (300 - 1,000 Hz)
Thumbnail Spectrum	Fmax: 150, 300, 600, or 1,000 Hz
High Resolution Vibration Spectrum	Fmax: 1,000 Hz Resolution: 800 or 1,600 lines Snapshot or Averaged (4 readings)
High Resolution Vibration Waveform	All measurements based on high resolution waveform with 4,096 points
High Resolution PeakVue Spectrum	Bandwidth: 1,000 - 20,000 KHz Fmax: 1,000 Hz Resolution: 1,600 lines Snapshot of impacting on machine
High Resolution PeakVue Waveform	Sampled at 51,200 Hz; High resolution with 4,096 points
Display	
Units	English, metric or SI
Local Display	The optional five-digit integral LCD display provides readout of HART parameters in engineering units (°F, °C, in/sec, mm/sec, g's and m/s ²). Display updates for each transmission Maximum update rate - once per minute
Update Rate	Standard: 1 min to 60 min (User selectable) Power Save: up to 24 hours (User selectable)
Operating Conditions	
Relative Humidity	0 - 95%
Temperature	Storage Temperature: -40°F to 185°F (-40°C to 85°C) Operating Temperature without LCD meter: -40°F to 185°F (-40°C to 85°C) Operating Temperature with LCD display: -4°F to 176°F (-20°C to 80°C)

Physical Specifications

Power Options:				
SmartPower™ Module	Intrinsically safe Replaceable Lithium-Thionyl Chloride			
External DC-power	Input Voltage: 10 - 28 VDC Provides unlimited operating life — recommended for applications requiring faster update rates			
Operating Life¹				
Configuration	1	2	3	
Overall Values (min):	30	60	120	
Energy Bands (hr):	8	8	8	
Spectrum (hr):	24	24	24	
Waveform (days)	30	30	30	
Operating life (years)	3.5	6	9	
Materials Of Construction:				
Enclosure	Housing — Low-copper aluminum Paint — Polyurethane Cover O-ring — Buna-N			
Terminal Block and Battery Pack	PBT			
Antenna	PBT/PC integrated omni-directional antenna			
Mounting	Vibration sensor must be mounted directly on asset being monitored Transmitter may be mounted up to 100' (30.5 m) away from sensor			
Weight	4.6 lbs. (2 kg) without LCD 4.7 lbs. (2.1 kg) with LCD			
Enclosure Ratings	NEMA 4X/IP66			
Performance Specifications				
ElectroMagnetic Compatibility (EMC)	Meets all relevant requirements of EN 61326.			
Measurement Accuracy ²	RMS Velocity: +/- 0.4 dB (Corresponds to +/-4%) PeakVue: +/- 0.4 dB (Corresponds to +/- 4%) Temperature: +/- 4°C			
Measurement Precision	Vibration: +/- 0.2 dB over 24 months Temperature: +/- 2°C over 24 months			
Self Calibration	The analog-to-digital measurement circuitry automatically self-calibrates for each update by comparing the dynamic measurement to internal reference elements			
Vibration Effect	No loss in functionality when tested per the requirements of IEC60770-1 with high vibration level (10 Hz to 10 KHz) and up to 50g acceleration			

(1) Operating life with a single SmartPower Module based on a configuration with two accelerometers and running at an ambient temperature of 70°F (21°C). Continuous exposure to extreme temperatures may reduce operating life by up to 20 percent.
 (2) Measurement accuracy is the absolute accuracy of the measurement relative to a known, calibrated excitation for WirelessHART devices. Values shown represent the expected performance operating under steady-state conditions (20°C with no external interference) for a mid-band excitation (nominally 1 g at 100 Hz).

Sensor and Connections

A0394 Sensor Series	
Nominal Sensitivity:	25 mV/g (2.5 mV/m/s ²)
Frequency Range:	96 to 600 Kcpm (1.6 to 10 kHz)
Amplitude Range:	± 100 g (± 980 m/s ²)
Broadband Resolution:	3 mg rms (0.03 m/s ² rms)
Settling Time:	≤ 2 sec
Temperature Range:	-40 to +250°F (-40 to +121°C)
Weight:	0.81 oz (23 gm)
Sensor Type:	Low profile, side exit integral cable

Terminal Block Connections

Two options for Terminal Block:

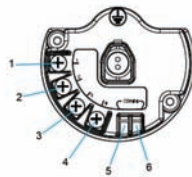

For SmartPower Module

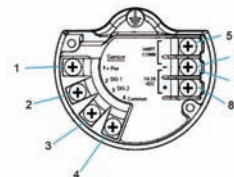

For External DC Line Power

Configuration 1: Single Vibration Sensor	Connector 1: Red wire Connector 2: White wire Connector 3: Open Connector 4: Black wire
Configuration 2: Single Vibration Sensor with Temperature	Connector 1: Red wire Connector 2: White wire Connector 3: Green wire Connector 4: Black wire
Configuration 3: Two Vibration Sensors	Connector 1: Red wires (2 total) Connector 2: White wire (Sensor 1) Connector 3: White wire (Sensor 2) Connector 4: Black wires (2 total)
HART Connection	Connectors 5 & 6
External Power	Connector 7: Negative Connector 8: Positive

Product Certification and Registrations

General Certifications	
Approved Manufacturing Locations	Emerson Process Management Knoxville, Tennessee USA
Telecommunication Compliance	2.4 GHz WirelessHART FCC ID: LW2RM2510 IC ID: 2731A-RM2510
ATEX Directive (94/9/EC)	Emerson Process Management complies with the ATEX Directive.



Compliant to Electro Magnetic Compatibility (EMC) (2004/108/EC)
All Models conforming to the following standards: EN 61326-1, 61326-2-3: 2006

Country	Restriction
Bulgaria	General authorization required for outdoor use and public service.
Italy	If used outside of own premises, general authorization is required.
Norway	May be restricted in the geographical area within a radius of 20 km from the center of Ny-Alesund.
Romania	Use on a secondary basis. Individual license required.
Radio and Telecommunications Terminal Equipment Directive (R&TTE)(1999/5/EC)	Emerson Process Management complies with the R&TTE Directive.
Canadian Standards Association (CSA)	General Safety Standard Certification conforming to the following standards: CSA Std. C22.2 No. 61010-1-4 Safety Requirements for Electrical Equipment for Measurement, Control and Laboratory Use, Part I : General Requirements (Second Edition) ISA S82.02.01 2nd (IEC 61010-1 Mod) Safety Standards for Electrical and Electronic Test, Measuring, Controlling and Related Equipment – General Requirements ANSI/UL Sta. 61010-1 Electrical Equipment for Measurement, Control and Laboratory Use: Part 1 General Requirements (Second Edition)

Hazardous Location Certification³ (Rev 4)

<p>Factory Mutual (FM)</p>	<p>Intrinsically Safe for use in Class I, Division 1, Groups C and D; Class I, Division 2, Groups A, B, C, D Intrinsically Safe for Class I, Zone 0, AEx ia IIB; Hazardous (Classified) Locations Temperature Codes T4 (-40 °C < Ta < 85 °C) T5 (-20 °C < Ta < 80 °C) with LCD Ambient temperature limits: -40 to 80 °C For use with Emerson Battery Pack Model 701PBKKF Only Enclosure Type 4X / IP66</p>
<p>Canadian Standards Association (CSA)</p>	<p>CSA for Class I, Division 1, Groups C, D Temp Code T4 (-40 °C < Ta < 85 °C) (-20 °C < Ta < 80 °C) with LCD For use with Emerson Battery Pack Model 701PBKKF Only Enclosure Type 4X / IP66</p>
<p>ATEX</p>	<p>ATEX Category Marking: II 1 G Ex ia IIB T4 (-40 °C < Ta < 85 °C) (-20 °C < Ta < 80 °C) with LCD For use with Emerson Battery Pack Model 701PBKKF Only</p>
<p>IECEX</p>	<p>IECEX Category Marking: Ex ia IIB T4 Ga (-40 °C < Ta < 85 °C) (-20 °C < Ta < 80 °C) with LCD For use with Emerson Battery Pack Model 701PBKKF Only</p>
<p>Other</p>	<p>Hazardous Area approvals pending for Brazil and Japan. A non-rated version of the CSI 9420 is also available, which can be operated with either the SmartPower Module or using external line-power (10-28V DC).</p>

(3) Consult factory for most recent information on individual approvals as well as special instructions.

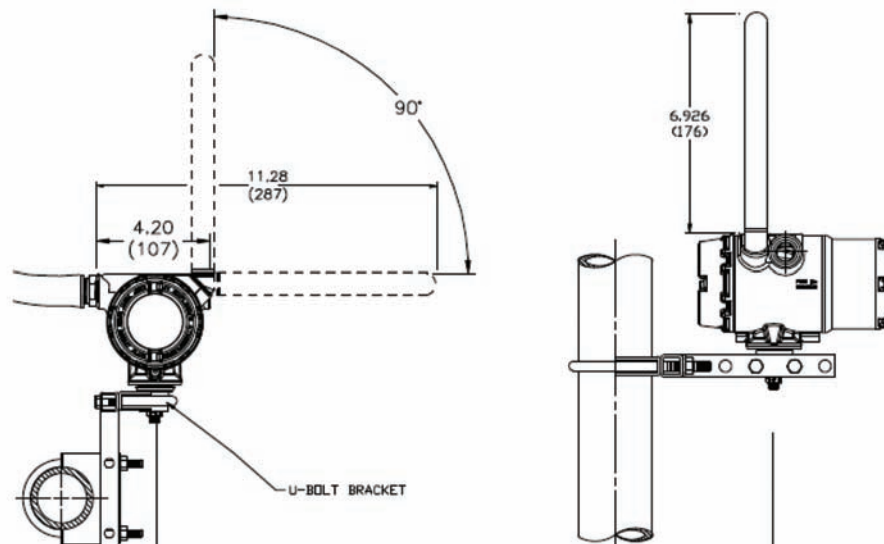

CSI 9420 dimensional drawing

Are You Wireless?

As any plant manager will tell you, you can't improve something if you can't measure it. Improved access to information provides the opportunity to reduce operating costs while improving quality, throughput, and availability. Add to that the expanding requirement to certify compliance with new environmental and safety standards. This all points to the need for increased monitoring, yet many managers still believe that the costs outweigh the benefits.

With wired systems, that may have been the case; however, wireless networks remove traditional barriers and redefine the cost equation. A wireless network can substantially reduce engineering, material, and implementation costs, and those cost savings are just the beginning.

Imagine what you can do with the additional information. Wireless technology can reduce – if not eliminate – the “blind spots” in your plant, while empowering mobile workers by providing needed information. The CSI 9420 provides predictive diagnostics for your essential production assets from virtually any location. The result is increased process uptime, improved consistency, and reduced risk of abnormal situations. As more and more plants are turning to wireless solutions, the question is “Are You Wireless?”



A CSI 9420 is an easy addition to any existing wireless network.

Emerson Process Management
Asset Optimization
835 Innovation Drive
Knoxville, TN 37932
T (865) 675-2400
F (865) 218-1401
www.assetweb.com

©2012, Emerson Process Management.

The contents of this publication are presented for informational purposes only, and while every effort has been made to ensure their accuracy, they are not to be construed as warranties or guarantees, express or implied, regarding the products or services described herein or their use or applicability. All sales are governed by our terms and conditions, which are available on request. We reserve the right to modify or improve the designs or specifications of our products at any time without notice.

All rights reserved. AMS, PlantWeb, Machinery Health, SNAP-ON, SmartPower, DeltaV, THUM, Ovation, and PeakVue are marks of one of the Emerson Process Management group of companies. The Emerson logo is a trademark and service mark of Emerson Electric Co. All other marks are the property of their respective owners.